



# 2" BORE ACCESSORIES



## MOUNTING NUTS

### Stud Nut

Part Number	Across Flats	Nut Thickness	Nut (Thread)
<b>N20-12</b>	1 3/4"	7/16"	1 1/4-12

### Rod Nut

Part Number	Across Flats	Nut Thickness	Nut (Thread)
<b>N08-20</b>	3/4"	5/16"	1/2-20

## CB-3295

Clevis Bracket  
Material: Steel, bright zinc plated

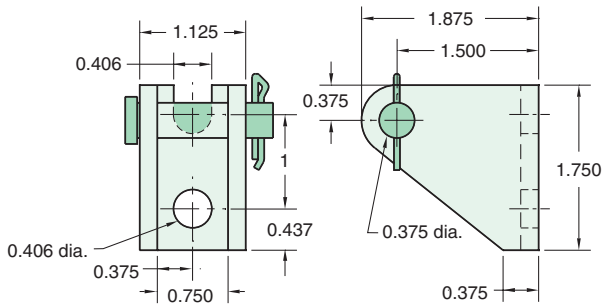

## RK-3299

Replaceable Rod Seal  
Material: Aluminum body

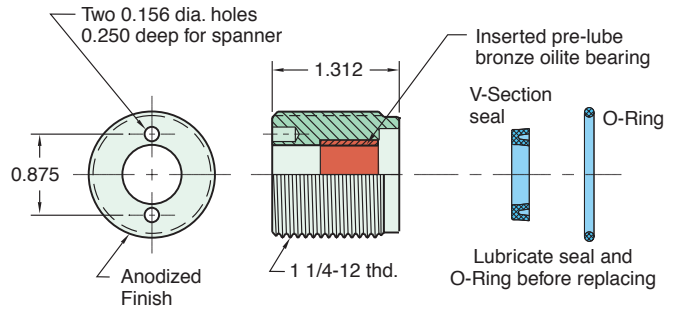

## RC-3281

Rod Clevis  
Material: Steel, electroless nickel plate

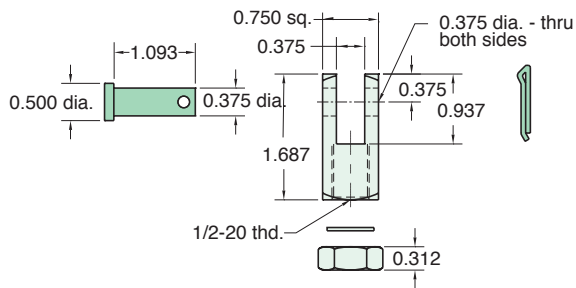

## RE-3285

Rod End  
Material: Steel, bright zinc plated body

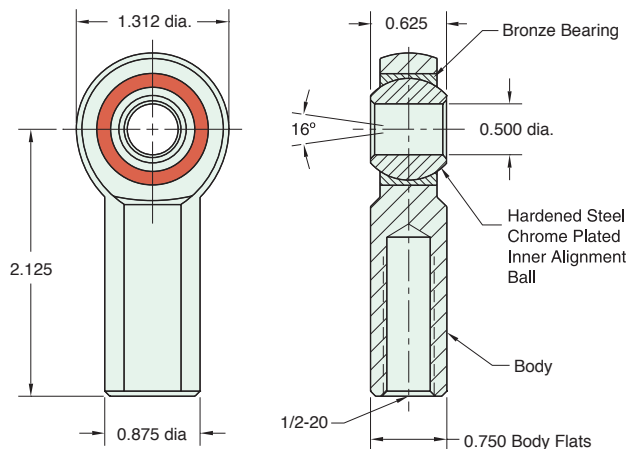

Lockwasher

Locknut

Max. Static Radial Load: 6700 lbs.  
Fits Rod Thread Size: 1/2-20

## FB-3291

Foot Bracket  
Material: Steel, bright zinc plated

